

LT - Arc - Cubic - 202 SurroundLite™ LED BOARD REPLACEMENT INSTRUCTIONS

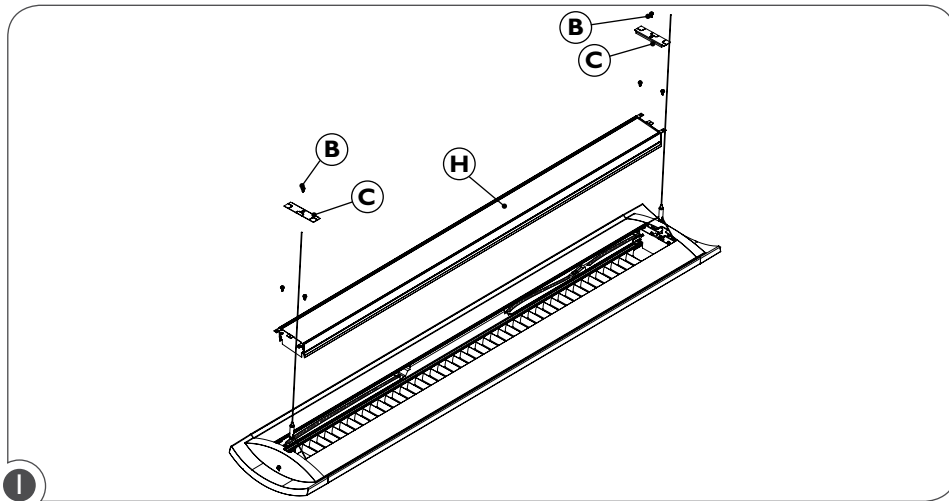

Remove top cover retaining screws (B) with a screwdriver and remove top covers (C) and optical engine (H).

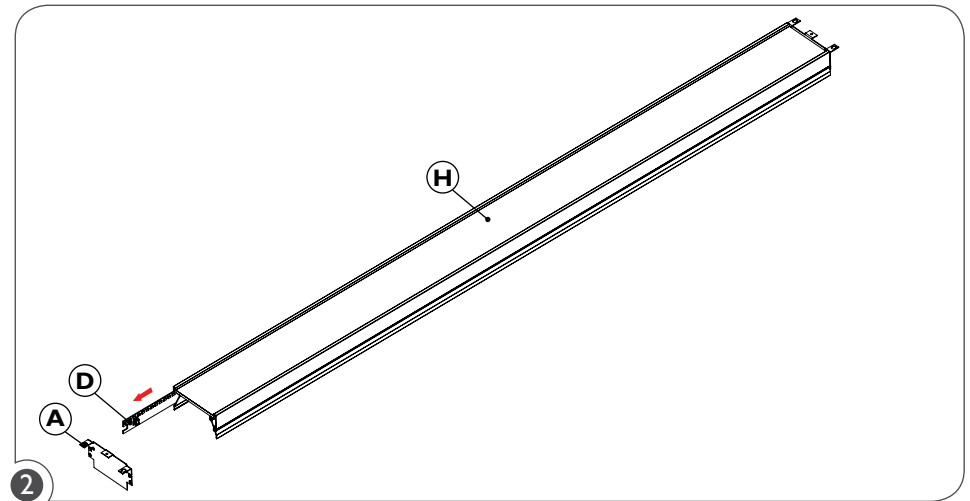

Remove one end plate (A) from the optical engine (H) and slide LED boards (D) out of the side channel. Disconnect quick connectors and re-connect all new boards. Make sure they have proper orientation - with LED row aligned with LED's on adjacent boards. Slide boards back in the side channel and re-attach the end plate.

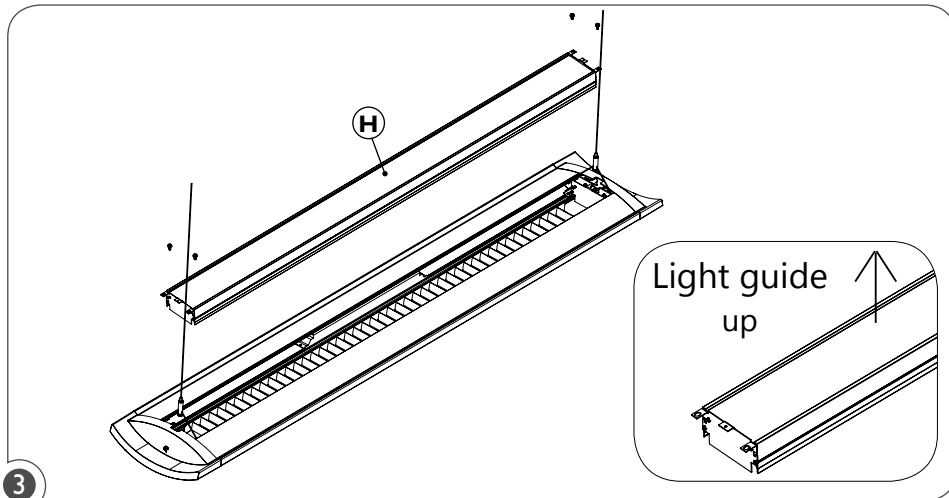

Re-attach optical engine (H) in the same orientation (light guide up).

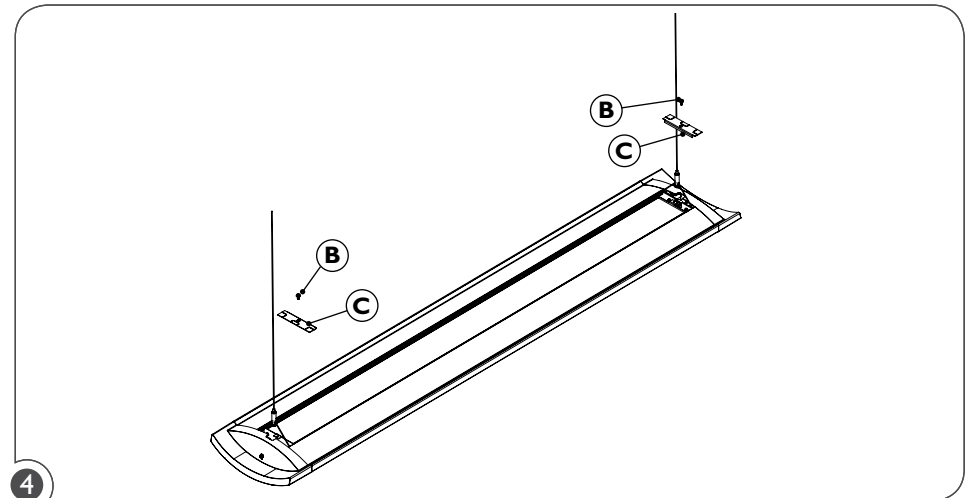

Re-attach top covers (C) and secure with top cover retaining screws (B).